

# Quantum Teleportation: Applications and Challenges



Hamdy Amin, STEM High School for Boys, 6<sup>th</sup> of October

## Abstract

*Quantum teleportation plays a crucial role in information science for its property of completely secure transmission. It was first demonstrated as a means of transferring the quantum state. Later, it has been extended greatly in the field of quantum computing, quantum network, and quantum communication, and other fields. The first part of this article will talk briefly about the basic theory of quantum teleportation and the applications that have been achieved in recent years for both commercial and scientific purposes. Next, the results of current experiments and the challenges that should be overcome in the future will be presented. The final section will be a discussion about the development of quantum teleportation and its future implementations.*

## I. Introduction

Numerous questions about information transfer have been raised from the quantum entanglement now between EPR pairs. It is impossible to deliver information simultaneously over a long range, but it is feasible to take quantum entanglement as a protocol to encrypt information. In 1993, physicists Asher Peres and William Wootters first proposed the concept of quantum teleportation. In their paper, the way to achieve quantum teleportation could be generally explained as measuring an unknown quantum state of a system then reconstructing it at a remote location. But the teleportation is only meaningful in the perspective of quantum information for the reason that the original particle does not move physically, and the state is changed. More importantly, the process of teleportation requires two channels, a traditional one and a quantum one. The traditional channel is used to transport the result yielded from the Bell measurement. And the quantum protocol is used in the unitary transformation to retrieve the original state and information.

The 1997 quantum teleportation was first verified by Dik Bouwmeester experimentally through pairs of entangled photons. Later, it

suddenly became a hot spot in information science. Not only does quantum teleportation provide a complete secure information transmission but also it boosts the development of quantum technologies. From the perspective of traditional communication protocol, it is a revolutionary watershed. In the point of quantum technologies, it serves as an indispensable foundation. Lots of technologies like quantum gate teleportation, computing, port-based teleportation, and quantum networks are derived from the basis of quantum teleportation. Quantum teleportation has been achieved in many laboratories with different approaches. With the great progress of the experiment, some extensions of quantum teleportation have been brought to the real world for commercial and scientific purposes.

## II. Theory of quantum teleportation

For simplicity, the sender and receiver will be called Alice and Bob. In the preparation process, Alice prepares an EPR pair (particle A, particle B) and particle C that carries the information which needs to be transferred. Then, Alice performs a joint measurement which is also known as Bell measurement with particle A and particle C, and gets a result that is used to transport. Since the state of particle C is changed, the technique survives the no-

cloning principle of quantum mechanics. After Bob gets the outcome of the Bell measurement from Alice through the traditional protocol, Bob can apply the unitary transformation to the result with his particle B to retrieve the state of particle A and the information contained in particle C.

What is presented in figure #1 is a basic approach to teleportation. Some components like the Bell measurement and unitary transmission are compulsory for it but the approach to achieve teleportation may be various when different setups are adopted.

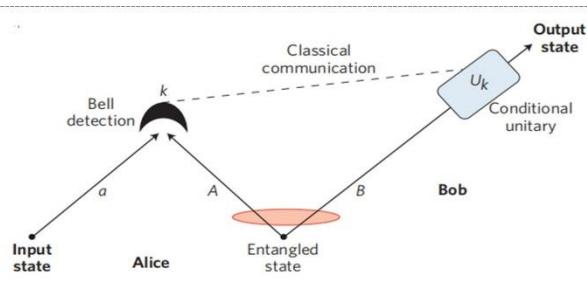

Figure #1: Theory of quantum teleportation

### III. Applications

#### i. Quantum network

In 2016, a scientific team in China successfully achieved quantum teleportation in relatively long-range communication using the existing fiber network. Almost at the same time, the Canadian scientific team also achieved quantum teleportation independently for several kilometers using a slightly different from the previous one.

And China's 'first commercial quantum private communication network' was built for national defense, finance, and other aspects in 2017. Their success may serve as an important milestone in building an international quantum network in the real world.

#### ii. Quantum computing system

In 2019, IBM revealed a quantum computing system named 'IBM Q' which is the first industrial-grade system built with integrated commercial universal quantum systems for business and science applications. It is a critical step towards the quantum computing system to break off from the lab.

### IV. Experimental status

#### i. Teleportation between light and matter

A scalable quantum network requires numerous nodes and those nodes may be far away from each other; thus, long-range teleportation is of importance.

One study demonstrates the teleportation between light and matter. In this experiment, shown in figure #2, an entangled pair is generated from the interaction between pulse and coherent atoms. In the transmitting section, the entangled light transmitted by atoms and pulse is mixed with a 50/50 beam splitter. The outcome of a Bell measurement in the form of homodyne measurements of the optical fields in the two output ports of the beam splitter is sent to the receiver through the classical channel. Results of this experiment show that the fidelity of 0.58 when  $n=20$  and fidelity of 0.60 when  $n=5$  is achieved, where  $n$  is the photon number.

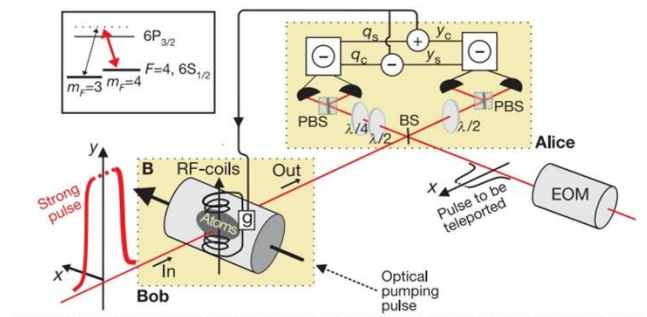

Figure #2: Setup of teleportation between light and matter

Another study focuses on diamonds. In this experiment, each node of teleportation is diamond with a nitrogen-vacancy center surrounded by carbon nuclei. And the nitrogen impurity provides a magnetic field to the electron enabling the entanglement between the hyperfine coupled electron and carbon spins under a zero magnetic field. In this study, the quantum state encoded in the emitted photon is transferred into carbon through the absorption of the electron which is entangled with the carbon nucleus on another node.

The teleportation works between a photon and the diamond serves as a bridge that connects microscopic particles and the macroscopic world.

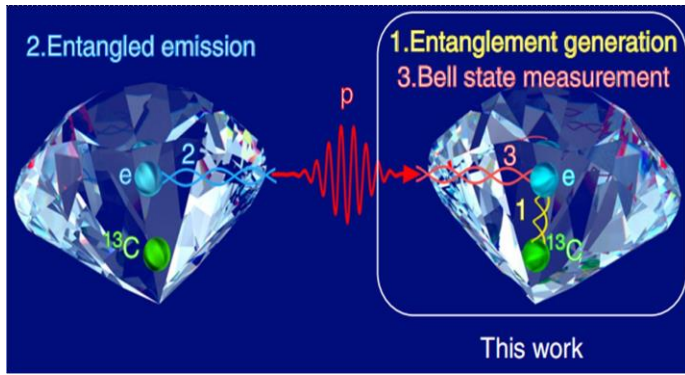

Figure #3: Process of teleportation between light and diamond

More applications could be realized in the field of quantum information technologies with the increasing size of teleportation.

### ii. High dimension teleportation

As previous experiments established, most of the experiments are limited to two-dimensional teleportation. This has been a stumbling block for the development of quantum technologies. For instance, a large number of small gates are required for simple computation, which badly influences the development of multiple qubit computers. And each particle can only carry a few pieces of information, which lowers the efficiency of communication. There is one solution that can improve the performance of the communication system and reduce the number of gates in quantum circuits, and that is to improve the dimensions of quantum states.

One study reports the experimental teleportation of a qutrit seen in figure #4 and proposes a scheme for high-dimensional quantum states. In three-dimensional teleportation, the first step is producing three-dimensional entangled pair and an ancillary photon using the nonlinear crystal. And the input qutrit states used to teleport and the ancilla photon is prepared by using the polarization-dependent beam displacers manipulated by half and quarter-waveplates. Then, Alice can transmit to Bob. And Bob implements the unitary transformation to recover the original state of Alice's teleported photon and the original information that Alice wishes to

teleport. Average fidelity of 0.75 is achieved under this condition.

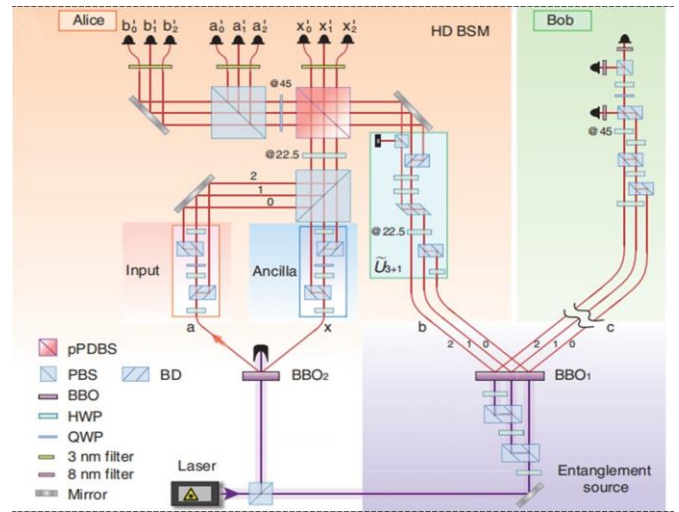

Figure #4: Experimental setup of high-dimensional teleportation

By using the scheme proposed in this paper, the quantum technologies could be extended to a higher dimension so that the efficiency of simulation and computation will be improved. The high-dimensional quantum states also mean large information contained in single-particle more capacity and noise resilience of the quantum communication system.

### V. Challenges

For optimal quantum teleportation, many conditions should be satisfied.

- There is no limitation to the input information.
- The input information and output can be supplied and verified by the third party except for the sender and receiver.
- A complete Bell measurement is achieved.
- Conditional unitary transmission could be performed before the verification from the third party.
- The fidelity of teleportation should be higher than the appropriate threshold of the classical protocol.

In many cases, only a few subsets of the Bell measurement are feasible and the feed-forward is either unaccomplished or simulated in post-

processing, thus the conditions (3) and (4) are not satisfied generally.

When it comes to reality, the problem that emerged in teleportation may be slightly different. While scaling up the dimension from 2 to N, for instance, one thing that should be considered carefully is whether all N dimensions still can form a coherent superposition to maintain the teleportation intact. For genuine N-dimensional teleportation, the scheme may need to combine some hypotheses that only fit in N dimensions with some basic hypotheses that can be applied to all dimensional teleportation. There are other issues to consider like the propagation losses of light and the atomic coherence lifetime raised from the classical protocol.

## VI. Conclusion

More than two decades have passed since the concept of quantum teleportation was proposed and verified. Now branches of it like quantum gate teleportation, quantum computing, port-based teleportation, photonic qubits, photonic qubits, optical modes, nuclear magnetic resonance, atomic ensembles, and trapped atomic qubits are achievable both theoretically and experimentally. The technologies mentioned above performed well in some aspects and failed in others, therefore certain technologies only correspond to a certain kind of practical situation. For example, trapped atomic qubits are appreciated in the quantum circuit for their short-term interaction, high fidelity, and relatively long quantum memory. While constructing a scalable quantum network, the atomic assembly is the preferred candidate for its long-range interactions.

Those technologies are imperfect more or less in some aspects, which raises lots of engineering questions as most of them are expected to be solved when more experiments are devised. Future aspects of quantum teleportation might focus on long-range

quantum teleportation between light and macroscopic matter or even quantum energy teleportation proposed in recent years.

## VII. References

- [1] Einstein A Podolsky B & Rosen N 1935 Can quantum-mechanical description of physical reality be considered complete? *Physical review* **47**(10) p 777
- [2] Bennett C H Brassard G Crépeau C Jozsa R Peres A & Wootters W K 1993 Teleporting an unknown quantum state via dual classical and Einstein-Podolsky-Rosen channels *Physical review letters* **70**(13) p 1895
- [3] Bouwmeester D Pan J W Mattle K Eibl M Weinfurter H & Zeilinger A 1997 Experimental quantum teleportation *Nature* **390**(6660) pp 575–579
- [4] Sun Q C, Mao Y L, Chen S J, Zhang W, Jiang Y F, Zhang Y B & Jiang X 2016 Quantum teleportation with independent sources and prior entanglement distribution over a network *Nature Photonics* **10**(10) pp 671–675
- [5] Valivarthi R Zhou Q Aguilar G H Verma V B Marsili F Shaw M D ... & Tittel W 2016 Quantum teleportation across a metropolitan fibre network *Nature Photonics* **10**(10) 676.2
- [6] quantumidUSKCN1BO0CT SEPTEMBER-13, 2017, [Accessed on April 26, 2020]
- [7] IBM Unveils World's First Integrated Quantum Computing System for Commercial Use 2019 [Online] Available <https://newsroom.ibm.com/2019-01-08-IBM-Unveils-Worlds-FirstIntegrated-Quantum-Computing-System-for-Commercial-Use>, Jan. 8, 2019[Accessed on April 26, 2020]
- [7] Pirandola S Eisert J Weedbrook C Furusawa A & Braunstein S L 2015 Advances in quantum teleportation *Nature photonics* **9**(10) 641
- [8] Lanyon B P Barbieri M Almeida M P Jennewein T Ralph T C Resch K J ... & White A G 2009 Simplifying quantum logic using higher-dimensional Hilbert spaces *Nature Physics* **5**(2) pp 134–140
- [9] Sherson J F Krauter H Olsson R K Julsgaard B Hammerer K Cirac I & Polzik E S 2006 Quantum teleportation between light and matter *Nature* **443**(7111) pp 557–560